

ASSEMBLY INSTRUCTIONS

WILWOOD COMPONENT BRAKE KIT WITH ZERO OFFSET® CALIPER BRACKETS

13.00" & 14.00" FRONT BRAKE KIT

WARNING

INSTALLATION OF THIS KIT SHOULD **ONLY** BE PERFORMED BY PERSONS EXPERIENCED IN THE INSTALLATION AND PROPER OPERATION OF DISC BRAKE SYSTEMS. IT IS THE RESPONSIBILITY OF THE PERSON INSTALLING ANY BRAKE COMPONENT OR KIT TO DETERMINE THE SUITABILITY OF THE COMPONENT OR KIT FOR THAT PARTICULAR APPLICATION.



FOR OFF ROAD USE ONLY

BEFORE OPERATING VEHICLE, TEST THE BRAKES UNDER CONTROLLED CONDITIONS. MAKE SEVERAL STOPS IN A SAFE AREA FROM LOW SPEEDS AND GRADUALLY WORK UP TO RACING SPEEDS. **DO NOT RACE ON UNTESTED BRAKES!** ALWAYS UTILIZE SAFETY RESTRAINT SYSTEMS WHILE OPERATING VEHICLE.

IMPORTANT

READ DISCLAIMER OF WARRANTY INCLUDED IN THE KIT.

WARNING: Some cleaners may stain or remove the finish on brake system components. Test the cleaner on a hidden portion of the component before general use.

*DRILLED ROTORS AVAILABLE; ADD "-D" TO END OF PART NUMBER WHEN ORDERING.

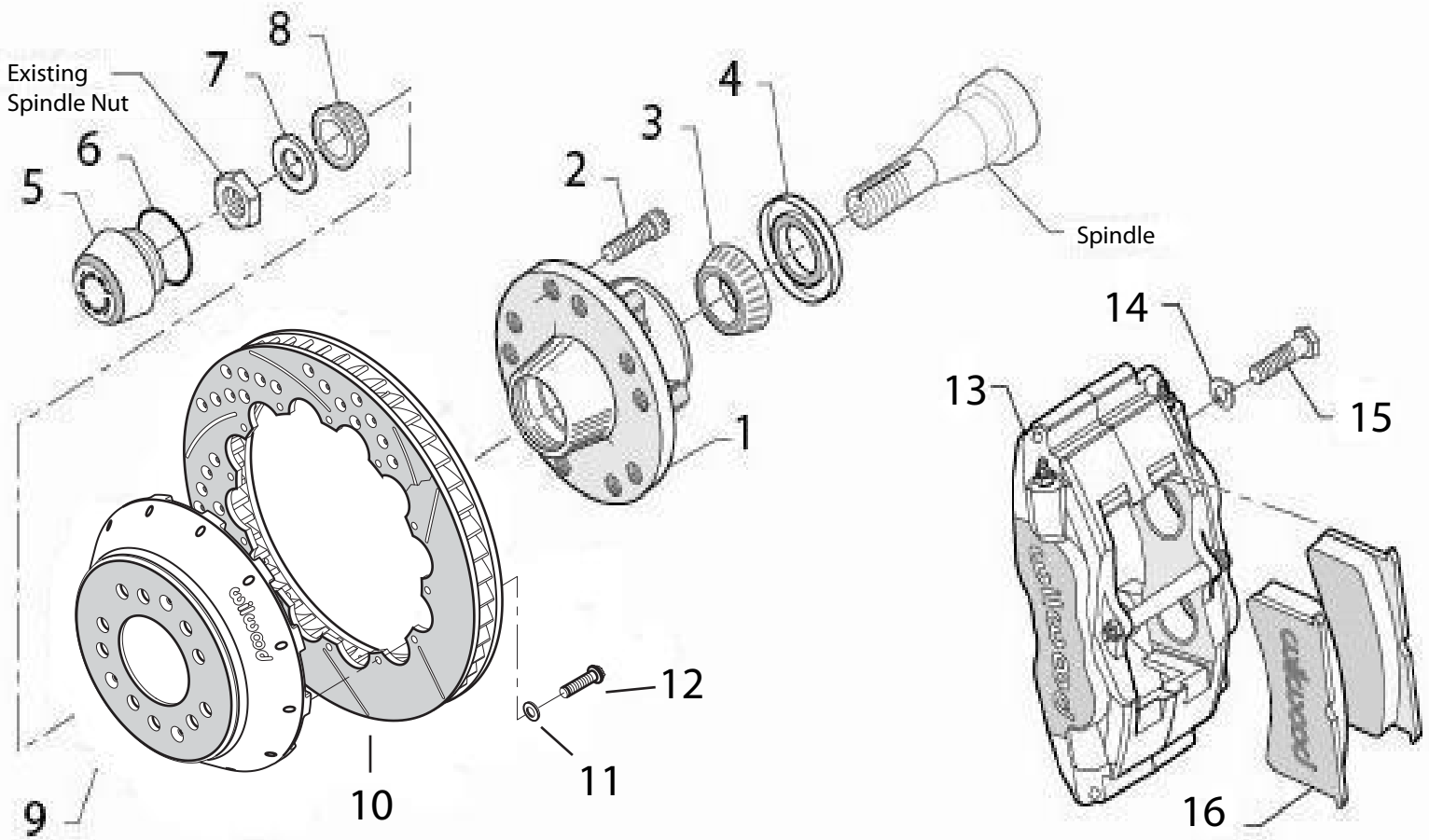

WARNING
 INSTALLATION OF THIS KIT SHOULD **ONLY** BE PERFORMED BY PERSONS EXPERIENCED IN THE INSTALLATION AND PROPER OPERATION OF DISC BRAKE SYSTEMS.

NOTE
 SPECIFIC PARTS MAY VARY FROM DIAGRAM

Figure 1. Typical Installation Configuration

<u>ITEM NO.</u>	<u>DESCRIPTION</u>	<u>QTY</u>
1	Hub Assembly	2
2	Stud, Wheel, 1/2-20 x 2.00 or 1/2-20 x 3.00 Long	10
3	Cone, Inner Bearing	2
4	Seal, Grease	2
5	Cap, Dust	2
6	O-ring	2
7	Washer, Spindle	2
8	Cone, Outer Bearing	2
9	Hat	2
10	Rotor	2
11*	Rotor Washer 1/4 or 5/16 (Not Required on 5/16 Applications)	Set
12*	Rotor Bolt 1/4 or 5/16	Set
13	Calipers	2
14a**	Washer, Shim	8
14b**	Washer, Lock	4
15**	Caliper Mount Bolt	4
16	Pads	4

* Rotor Bolt and Washer Kits Require 16, 20, or 24 pcs.

** Caliper Bolts, Shims and Washers are 3/8 or 7/16.

Note 1: Rotors can be Purchased Plain, Slotted Only, Drilled and Slotted or Floating

Note 2: Rotors can be Purchased with Stress Relieved and/or Balanced

Note 3: Drawing Shows Typical Hat and Rotor for 11.75" and 12.19" Rotors with 8 on 7" Mount

Note 4: Mounting of Bracket will Depend on Spindle Application

Note 5: Dry Fit All Parts Before Final Assembly

Note 6: See Specifications for Torque Requirements on Bolts with Safety Wire or Loctite

Important Notice - Read This First

Before any tear-down or disassembly begins, review the wheel clearance diagram (Figure 2, below right) to verify that there is adequate clearance with the wheels you will be using with this installation.

NOTE: Installation of this Wilwood kit will result in the wheels being moved out approximately one inch per side more than the stock brakes.

General Information and Assembly Instructions

Installation of this kit should **ONLY** be performed by persons experienced in the installation and proper operation of disc brake systems. Before assembling the Wilwood front disc brake kit, double check the following items to ensure a trouble-free installation.

Radius Clearance:

Caliper Clearance**:

Rotor Size	AP4 and Superlite	Dyna Pro 6	Caliper	Distance From Rotor to Face
11.75"	6.69"	6.78"	Dyna Pro 6	1.64"
12.19"	6.85"	6.94"	Narrow Superlite 6	1.79"-1.91"
12.90"	7.23"	7.20"	Superlite 6	2.41"
13.00"	7.29"	---	Forged Superlite & AP4	2.15"
14.00"	7.75"	---	W6A	1.98"

** To determine how much clearance you need in front of where the wheel mounts, subtract the measurement in column B from the hat offset.

- Make sure this is the correct kit to match the exact make and model year of the vehicles spindle.
- Verify the hub stud pattern in this kit (5 x 4.50 or 5 x 4.75) matches the stud pattern of the vehicles wheels.
- Verify wheel clearance.
- Inspect the package contents against the parts list to ensure that all components and hardware are included.

Assembly Instructions:

- Disassemble the original equipment front brakes:

Raise the front wheels off the ground. Support the front suspension by placing jack stands under the lower control arms. The lower control arms **MUST** be supported. The vehicle's weight must be on jack stands and not supported by a car jack or hoist.

Remove the center cap, cotter pin, nut lock and the wheel bearing nut and washer. Save the wheel bearing nut and nut lock. Remove the brake drum and hub assembly, including the wheel bearings. Disconnect the brake hoses from the brake line at the body. Remove the two upper backing plate retaining nuts and bolts. Remove the two lower ball joint to spindle nuts and bolts. The backing plate, spindle and ball joint will now separate. Remove the brake backing plate and shoes as an assembly. Reinstall the front ball joint bolt and nut. Do not tighten at this time. Do not reinstall the rear bolt and nut.

- Clean and de-grease the spindles.
- The spindle and caliper bracket have been loosely assembled for alignment purposes. Loosen the bolts that secure the brackets together so that the bolts are hand tight only, this will enable the bracket assembly to be adjusted to accommodate various spindle tolerances during assembly. Bolt the lower portion of the bracket assembly to the backing plate face of the spindle using bolts, washers, and lock nuts, hand tighten only. **NOTE:** Be sure the heads of the bracket assembly insert nuts are facing outward toward the wheel. Install bolt through caliper bracket, and into the steering arm. Torque two bolts to 47 ft-lb. Apply red *Loctite*® 271 to the bolt threads and torque to specifications. Remove one of the bolts that secure the bracket assembly to each other. Apply red *Loctite*® 271 to the bolt threads and reinsert into the bracket assembly. Repeat this procedure for the second bolt. Torque these bolts to specifications.
- Install five new wheel studs into the hub. Torque to 77 ft-lb. **NOTE:** There are two five lug patterns in the hub (5 x 4.50 and 5 x 4.75). Make sure of the correct hole pattern for the correct wheel application before installing studs into hub.

General Information and Assembly Instructions (Continued)

- Pack the large inner bearing cone with high temperature disc brake bearing grease (available from your local auto parts store) and install into the backside of the hub.
- Install the grease seal (8) by pressing into the backside of the hub (6).
- Pack the small outer bearing cone with high temperature disc brake bearing grease and install into the front side of the hub. Lightly coat the spindle bearing surfaces with bearing grease. Slide the hub assembly onto the spindle. Secure using spindle washer, existing adjusting nut and nut locking device. Adjust wheel bearing pre-load per Original Equipment Manufacturer (OEM) specifications.
- Install the o-ring and the dust cap into the hub. Friction created by the o-ring on the dust cap keeps it from unscrewing. The O.D. of the existing spindle washer may be larger than the I.D. of the dust cap which may allow the washer to contact the dust cap. Use the spindle washer supplied with the kit instead of the stock washer or modify stock washer.
- With the larger I.D. side of the rotor facing away from the hat, bolt rotor to hat through the backside of the rotor using bolts (The flat side of the lug should be facing toward the outside). Torque bolts to specifications. Safety wire bolts, see Figure 2.

- Slide the rotor/hat assembly over the wheel studs in the hub.

- With the bleed screws pointing up, mount the caliper onto the caliper bracket using two bolts, two lock washers and two shim washers. Finger tighten. View the rotor through the top of the caliper. The rotor should be aligned in the center of the caliper. If not, loosen the two bolts and adjust the caliper by using inch thick shim washers. The shim washers should be placed between the caliper and the caliper bracket. Finger tighten and recheck alignment. Loosen the two bolts and apply red *Loctite*® 271 to bolt threads and torque to specifications. Safety wire the bolts.

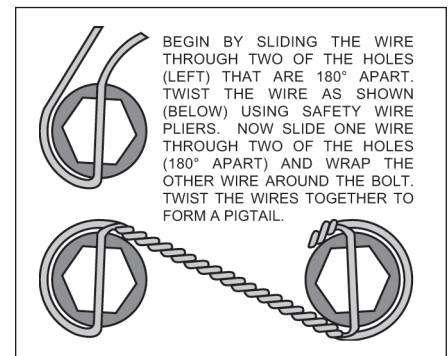

Figure 3. Safety Wire Diagram

- Install the disc brake pads into the caliper.
- **NOTE** : The caliper inlet hole has a 1/8-27 NPT thread. Steel adapter fitting should be installed in the caliper. We recommend Wilwood hose kit, part number 220-7699 to be used with this kit. **THE ORIGINAL EQUIPMENT PRODUCTION RUBBER BRAKE HOSES SHOULD NOT BE USED.**
- Repeat assembly procedure for the other wheel.
- Bleed the brake system (reference additional information on the last page if necessary).

Additional Information and Recommendations

- We recommend the Gorilla Performance Balance Bar Assembly on vehicles that do not have 18 Inches of Vacuum.
- We do not recommend using electric vacuum pumps on other devices that require electric or hydraulic power to operate.
- For more information please visit, www.gorillaperformance.com

Additional Information and Recommendations (Continued)

- With the Wilwood disc brake system completely installed, use either of the two methods listed to balance the brake bias front to rear.
 - The Most Efficient Method:**
A Wilwood brake pedal/balance bar assembly (either floor or swing mount) and two single master cylinders mounted side by side. Dialing the balance bar left or right transfers the pressure from front to rear, or rear to front and allows the smallest of pressure adjustments to be made without any loss to the overall brake system line pressure.
 - The More Popular Method:**
An OEM 1-1/16 inch bore dual outlet master cylinder with a Wilwood adjustable proportioning valve plumbed into either the front or rear brake line. **NOTE:** A proportioning valve is an in-line pressure reducing device. Output pressure is reduced proportionally to input pressure. Net result is that the line pressure is reduced, forcing the remaining brakes to do more of the work.
- Fill and bleed the new system with Wilwood Hi-Temp° 570 grade fluid or higher. For severe braking or sustained high heat operation, use Wilwood EXP 600 Plus Racing Brake Fluid. Used fluid must be completely flushed from the system to prevent contamination. **NOTE:** Silicone DOT 5 brake fluid is **NOT** recommended.
- To properly bleed the brake system, begin with the caliper farthest from the master cylinder. Bleed the outboard bleed screw first, then the inboard. Repeat the procedure until all calipers in the system are bled, ending with the caliper closest to the master cylinder. **NOTE:** When using a new master cylinder, it is important to bench bleed the master cylinder first.
- If the master cylinder is mounted lower than the disc brake calipers, some fluid flowback to the master cylinder reservoir may occur, creating a vacuum effect that retracts the caliper pistons into the housing. This will cause the pedal to go to the floor on the first stroke until it has “pumped up” and moved all the pistons out against the pad again. A Wilwood in-line two pound residual pressure valve, installed near the master cylinder will stop the fluid flowback and keep the pedal firm and responsive.
- Test the brake pedal. It should be firm, not spongy and stop at least 1 inch from the floor under heavy load.
 - If the brake pedal is spongy, bleed the system again.
 - If the brake pedal is initially firm, but then sinks to the floor, check the system for fluid leaks. Correct the leaks (if applicable) and then bleed the system again.
 - If the brake pedal goes to the floor and continued bleeding of the system does not correct the problem, a master cylinder with increased capacity (larger bore diameter) will be required. Wilwood offers various lightweight master cylinders with large fluid displacement capacities.
- NOTE:** With the installation of after market disc brakes, the wheel track may change depending on the application. Check your wheel offset before final assembly.
- On some models of disc brake spindles there are “ears” where the OEM calipers were mounted and these “ears” interfere with the assembly of the Wilwood disc brake kit. If it becomes necessary to remove these “ears”, remove as little as possible being careful not to cut away any of the mounting holes that may be required to bolt on the caliper mounting bracket.
- If after following the instructions, you still have difficulty in assembling or bleeding your Wilwood disc brakes, consult your local chassis builder, or retailer where the kit was purchased for further assistance.

PAD BEDDING PROCEDURE:

- Pump brakes at low speed to assure proper operation. On the race track, or other safe location, make a series of hard stops until some brake fade is experienced. Allow brakes to cool while driving at moderate speed to avoid use of the brakes. This process will properly burnish the brake pads, offering maximum performance.

Associated Components

PART NO.	DESCRIPTION
260-1874	Wilwood Residual Pressure Valve (2 lb for disc brakes)
260-1876	Wilwood Residual Pressure Valve (10 lb for drum brakes)
260-2220	Wilwood Proportioning Valve
290-0632	Wilwood Racing Brake Fluid (Hi-Temp° 570) (12 oz)
290-6209	Wilwood Racing Brake Fluid (EXP 600 Plus) (16.9 oz)
340-1285	Wilwood Floor Mount Brake Pedal (with balance bar)
340-1287	Wilwood Swing Mount Brake Pedal (with balance bar)
260-6764	Wilwood 3/4 inch High Volume Aluminum Master Cylinder
260-6765	Wilwood 7/8 inch High Volume Aluminum Master Cylinder
260-6766	Wilwood 1 inch High Volume Aluminum Master Cylinder
260-4893	1-1/16 inch Tandem Master Cylinder (aluminum housing)
250-2406	Mounting Bracket Kit (tandem master cylinder)
350-2038	1971 - 1973 Pinto Rack and Pinion (new, not rebuilt)
270-2016	Quick Release Steering Hub (3/4 inch shaft)
270-2017	Quick Release Steering Hub (5/8 inch shaft)
220-0149	Fitting, Straight (1/8-27 NPT to -4)
220-0842	Fitting, 90° Elbow (1/8-27 NPT to -4)
	(Consult the Wilwood Catalog for a complete parts list)

Bolt Torque Specifications

BOLT SIZE	TORQUE
1/4-20	85 in-lb
1/4-28	103 in-lb
5/16-18	180 in-lb
5/16-24	198 in-lb
3/8-16	22 ft-lb
3/8-24	30 ft-lb
7/16-14	42 ft-lb
7/16-20	47 ft-lb
1/2-13	65 ft-lb
1/2-20	77 ft-lb
9/16-12	95 ft-lb
9/16-18	105 ft-lb
5/8-11	110 ft-lb
5/8-18	120 ft-lb

NOTE: This bolt torque specification list is for use with specific grades of bolts as supplied in the particular Wilwood kit and is not intended as a guide for any other application.